



# Project "Agroindustry of long-term storage of fruit and vegetable products" (AIDH)

We offer a comprehensive solutions for launching joint venture production

# The main advantages of this project:

---

**1. Financially profitable:**

Investments in this project give a fast and high income for a long time.

**2. Social significance of the project:**

Implementation of the project provides food security and saving energy resources in any climatic conditions. Solves the problem of storage of fruit and vegetable products of long-term.

**3. Innovative Technology:**

The application of project technology, allows for rapid and efficient scaling of the project and production. Technology allows of long-term storage of fruit and vegetable products in difficult climatic conditions.

Massive integration of agricultural technologies  
for save food

Unique integrated solutions to the food, environmental, pandemic and climate security of States and territories

# The origins of scientific development:

---

Initial developments began on the initiative of the heads of Gov departments of fundamental research and strategic R&D of the Russian Federation back in early 2001.

As a result of many years of work, interrelated targeted large-scale projects were developed, technological and economic mechanisms for their implementation were worked out, industrial cooperation was formed. In total, about 120 cross-industry specialists are working on the project.

The project has an integrating character and allows to multiply the save long time of products agriculture.

Unique integrated solutions to the food, environmental, pandemic and climate security of States and territories

# Project "Agroindustry of long-term storage of fruit and vegetable products" (AIDH)

---

AIDH project provides for the stage-by-stage construction and operation at the customer's site of a complex of systems for long-term storage of fruit and vegetable products with a total capacity of 8 thousand tons, equipped with a line for production and bottling of live juices, as well as a line of sublimation and packaging.

On the territory of the object will be created: systems of autonomous power supply, infrastructure of access communications, parking lots, compact modern systems of small wholesale and retail trade, logistics, high-performance security systems, consisting of a complex of alarm and monitoring.

## **The design of the CWS complex**

The housing of the KSC facility is made of a solid encapsulated structure based on a new generation system-forming building material - foam silicate of different density, which is cast into the reusable curvilinear form work. Thickness The outer shells of the construction have a thickness of 700 mm, the inner partitions have a thickness of 400 mm.

Unique integrated solutions to the food, environmental, pandemic and climate security of States and territories

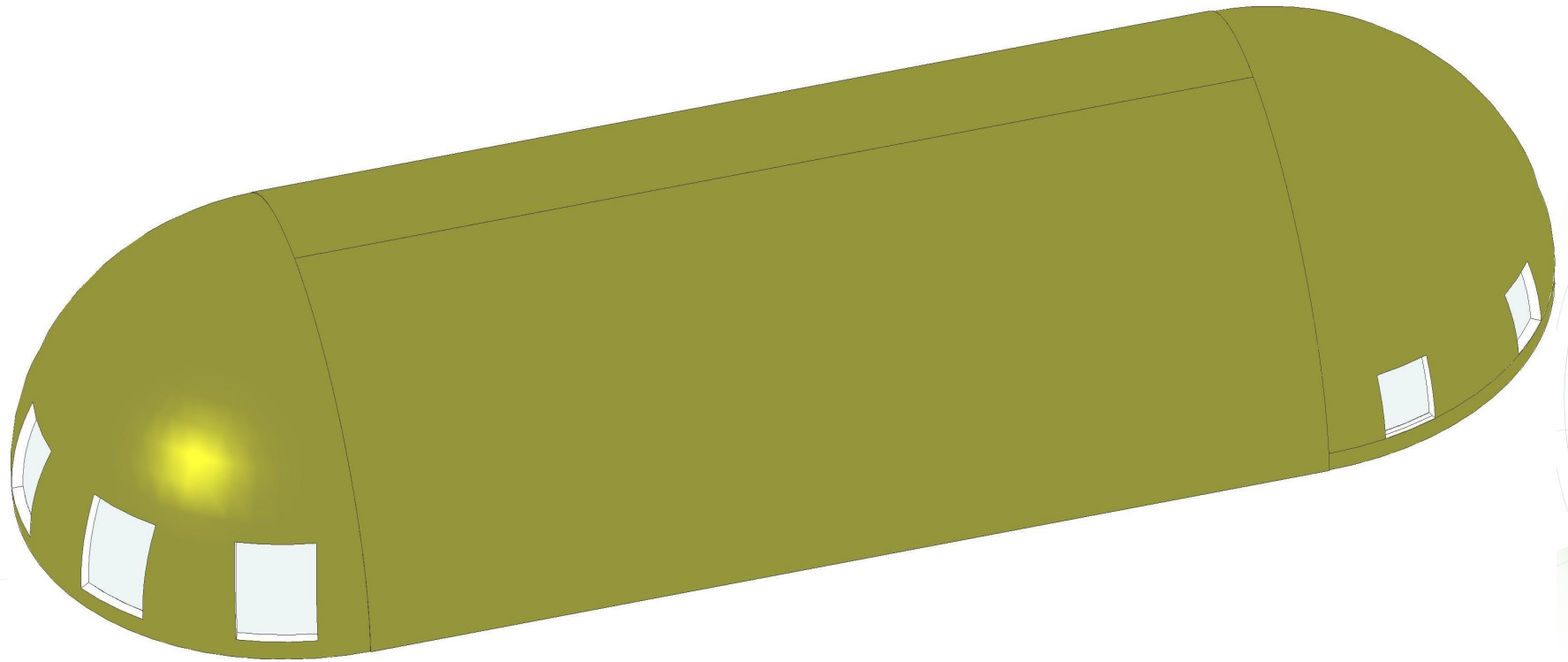

Exterior view of the complex for 1,000 tons of fruit and vegetable products with the production and bottling line of "live" juices.

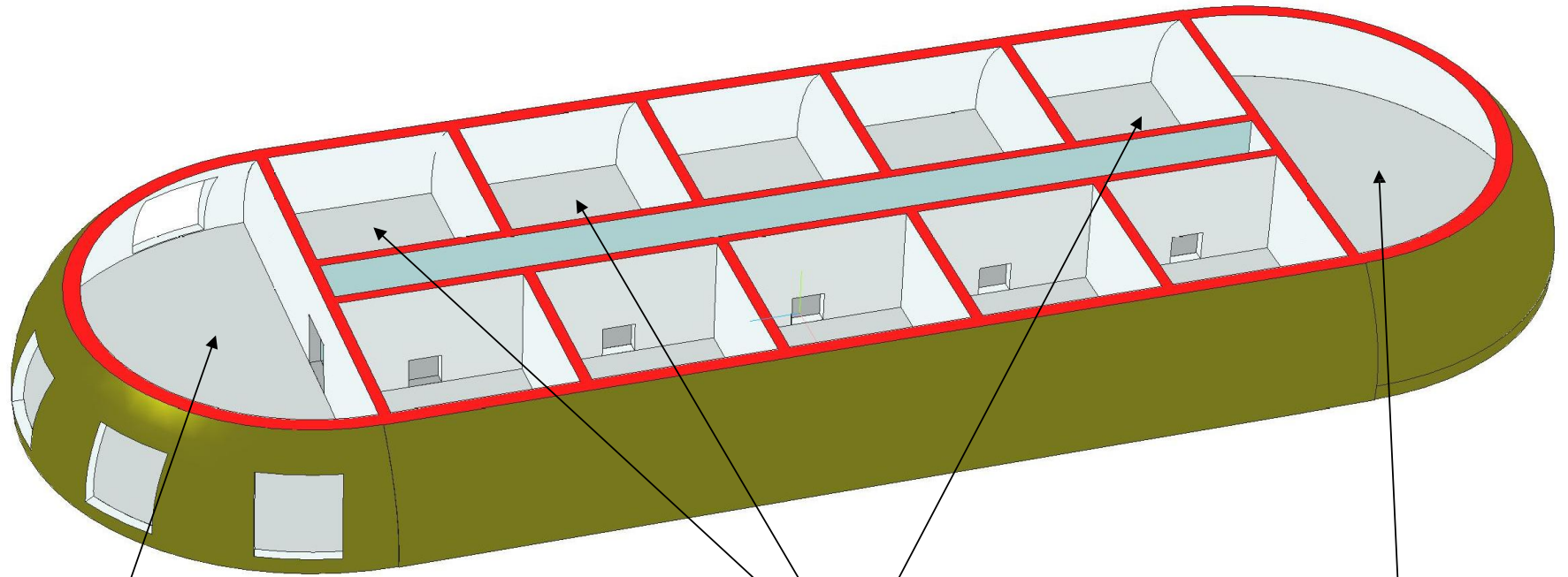

**The logistics booth**

**Temperature-controlled storage chambers No. 1-10 with gas media control systems and autonomous power supply systems**

**Production and bottling line for live juices**

## The total area of one storage facility for 1,000 tons in plan is 1,750 m<sup>2</sup> , including:

---

- 10 hermetically sealed insulated chambers for 100 tons of products or 20 storage chambers for 50 tons of products.

Taking into account the packing density of 1 ton of product in 6 m<sup>3</sup> per 1 m<sup>2</sup> , and the aisles and spaces between the storage containers, the total area of all cells would be 1300 m<sup>2</sup> . with a storage cell volume of 7800 m<sup>3</sup> .

- Logistics vestibule with an area of 225 meters (primary reception, sorting, washing, drying, placing in containers according to storage technology, as well as the return unloading of containers to consumers and for processing into juice or sublimation

- 225-meter tambour line for the production and bottling of "live juices" or sublimation and packaging of fruits and forest berries.

All chambers are equipped with containers of wood or plastic for storage and long-term storage of products at the rate of 250 kg per 1 container (for one storehouse 4000 containers in total).

## The total area of one storage facility for 1,000 tons in plan is 1,750 m<sup>2</sup> , including:

---

All chambers are equipped with cooling and thermoregulation systems (operating temperatures 1 - 6 C°), gas analysis systems for oxygen, carbon dioxide, as well as temperature and humidity sensors.

All chambers are equipped with special low-frequency emitters of EM waves, as well as systems for creating biocidal mists.

All chambers are equipped with TV cameras, special portal automated systems for loading and unloading containers through lock chambers.

All chambers are equipped with special heat-insulated sealed gates of high strength stainless steel.

All chambers are equipped with gas exchange systems according to the recirculation scheme and control systems, hardware formation and maintenance of regulated gas media separately:

- oxygen regulating installations RGS-K,
- carbon dioxide control units RGS-U,

Each storage facility as a whole has an automatic control and monitoring system, switchboard and electrical cabling equipment, as well as a backup power supply.

The repository is surrounded by a ring:

---

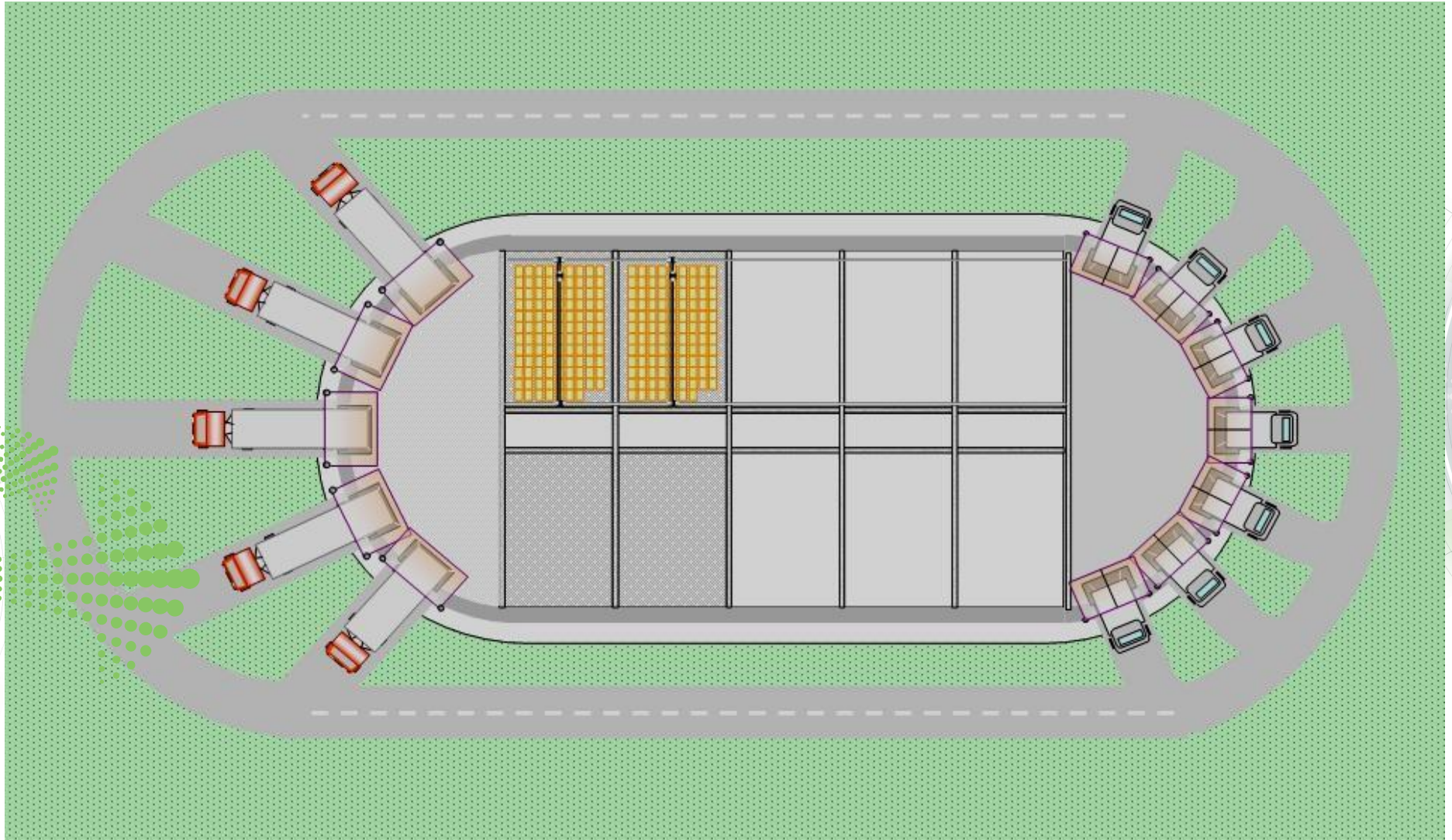

Effects of the use of new means of regulating gas media: -reduction of energy consumption for obtaining and maintaining a given gas medium-b4-5 times; providing ultra-low oxygen concentrations (0.6%) for effective storage of perishable fruits and vegetables.

24000

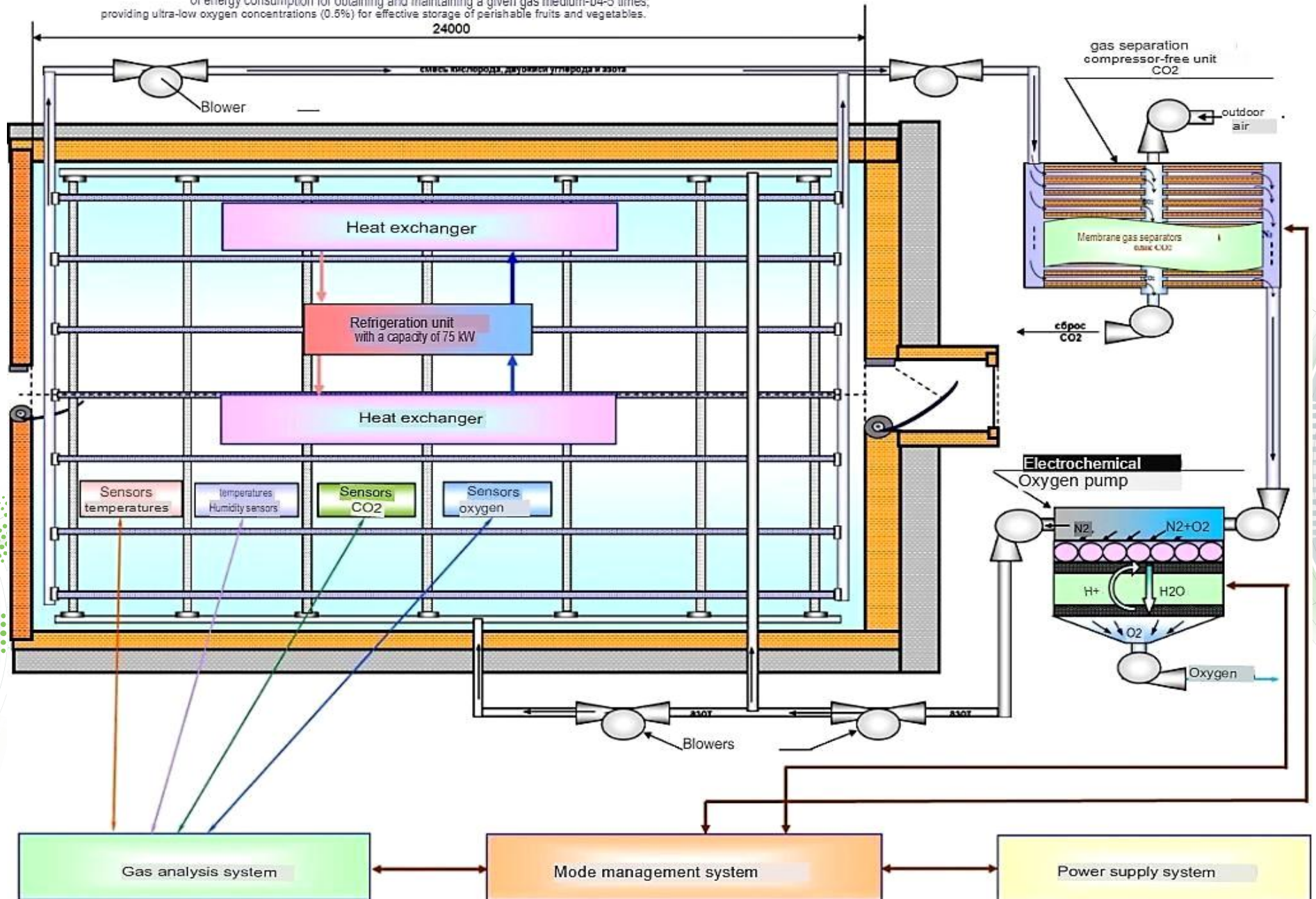

# Principle of operation and technical solutions of the CWS systems.

---

KSKH storage facility (hereinafter - the object) with a controlled atmosphere (RGS) is designed for long-term storage of fruit and vegetable products with a capacity of 100-1000 tons.

CWC systems perform separate two-parameter regulation of the gas composition of the atmosphere and consist, respectively, of two units:

Membrane unit for carbon dioxide removal from the regulated atmosphere (RGS-U).

The technology is based on a special development: highly selective gas separation membranes. The membranes contain a grafted immobilized chemisorbent group in their structure, which provides selective transfer of carbon dioxide from a controlled nitrogen atmosphere to the ambient air under the action of the partial pressure difference of carbon dioxide without the use of compression or vacuum pumping of gases. Energy consumption in the process of gas separation is reduced to the work of ventilation of the chamber atmosphere and ambient air, respectively, over the adsorbing and desorbing membrane surfaces and is 0.9-0.1 kWh/m<sup>3</sup> CO<sub>2</sub> with a minimum concentration of carbon dioxide in the controlled atmosphere (0.8...1.0% vol.).

Electrochemical Oxygen Removal Unit from Regulated Atmosphere (RGS).

The gas separation technology is an electrochemical oxygen

# Principle of operation and technical solutions of the CWS systems.

---

cycle:

- chamber atmosphere oxygen is chemically bound in the reaction of "cold" (+50...70° C) catalytic oxidation of hydrogen, which is generated at the cathode of electrolysis cells based on a modern solid polymer electrolyte (sulfocationic ion-exchange membrane);
- The product of the oxidation reaction - water - returns to the electrolysis cells, where it decomposes into hydrogen emitted at the cathode and oxygen, which is emitted in pure form at the anode of the cells and released into the atmosphere or can be used for technological needs.

Energy costs for the extraction of pure oxygen from the controlled atmosphere do not depend on its concentration in the atmosphere (up to 0.5...1% volumetric) and make 8...10 kWh/m<sup>3</sup> O<sub>2</sub>

The technologies provide minimum operating costs, especially at low oxygen concentrations in the chamber - 3...5 times lower than the costs of the best world analogues, as well as complete environmental purity of the controlled atmosphere.

The physical basis for energy efficiency is direct separation of gases from the storage chamber atmosphere, high gas separation selectivity and no gas compression. The capacity reserve of the systems for the volume of the object is not less than 50%.

# Product storage technology.

---

Storage of fruits and vegetables in a protective regulated gas environment (RGA), (i.e. environment with reduced oxygen content - no more than 5% by volume, carbon dioxide 1...5% by volume, the rest - nitrogen), puts these products in a state of biological anabiosis, suppresses microbial growth and processes of putrefaction and fermentation. As the available experience shows, in comparison with the conventional refrigerated storage this method allows to achieve the following effects:

- Guaranteed to preserve the vitamin, flavor, nutritional and consumer qualities of fresh products throughout the storage period;
- prolong the shelf life by 40...60% (up to 10 months depending on the type of products);
- increase the level of storage profitability from 18...20% to 100 -200%. In current world practice, the following products are stored in the RGS:
  - fruit - apples, pears, grapes, bananas, etc,
  - citrus fruits - oranges, lemons, tangerines, etc,
  - fresh vegetables - potatoes, carrots, onions, garlic, cabbage, cucumbers, tomatoes, eggplants, salads (a total of 45 species),

# Product storage technology.

---

- berries - gooseberries, strawberries, black chokeberries, cherries, plums, cherries, peaches, apricots, etc,
- grain with high moisture content (> 15%), seed and fodder (rice, wheat, rye, corn, barley, oats, etc.),
- oilseeds - sunflower, cotton, etc,
- food products - milk, milk powder, margarine, pork fat, butter, sunflower and cottonseed oil, steamed meat, chilled fresh fish and fish products, seafood, creams, cakes, fruit juices, beer, wine materials, instant tea and coffee, walnuts, almonds, chestnut, hops, etc,
- flowers - roses, gladioluses, tulips, etc,
- mixed fodder and its components - grass, fish, meat and bone meal, meal, cake, bran, yeast, protein and vitamin concentrates and additives.
- When storing apples, pears, grapes and other fruits in RGA, the oxygen content is: the lower limit is up to 1%, the upper limit is 5%. Carbon dioxide content varies more widely from 0.5 to 8%. Optimal humidity of RGS: 90...98%; temperature is slightly higher than when storing these products only in the cold: 2...4 C.
- Storing in RGA cuts vitamin C losses in half, preserves sugar much better, slows down hydrolysis of pectin substances, and reduces parasitic and physiological diseases.

# Comparative table of storage regimes and terms

Products	Storage T°, C°	Shelf life, days.	
		(traditional storage)	<b>RGS</b>
<b>Fruits</b>			
<b>Apples</b>	3 - 4	110 - 130	210 - 270
<b>Pears</b>	3 - 4	90 - 110	150 - 270
<b>Grapes</b>	1,0	80 - 100	180 - 240
<b>Ripe bananas</b>	10 - 15	5 - 10	35 - 43
<b>Mature lemons</b>		21 - 42	180
<b>Peaches</b>		7 - 28	90
<b>Plum</b>	1,0	30 - 60	70 - 100
<b>Cherry</b>	1,0	5 - 7	25 - 40
<b>Currant</b>	2 - 4	14 - 21	35 - 37
<b>Strawberry</b>	2 - 4	2 - 5	25 - 30
<b>Walnuts</b>		...	720
<b>Chestnuts</b>		...	180
<b>Almond</b>		...	400
<b>Vegetables</b>			
<b>Cabbage:</b>			
- white cabbage	1 - 3	160 - 180	210 - 240
- reddish	1 - 3	150 - 210	210 - 240
- Brussels	2 - 4	20 - 30	90 - 120
- colored	2 - 4	30 - 60	180
- Savoy	2 - 4	120	150
<b>Potatoes</b>	4	140	320
<b>Carrots</b>	2 - 3	120 - 150	240 - 270
<b>Onions</b>		150 - 210	240 - 270
<b>Garlic</b>		120 - 180	210 - 260
<b>Root celery</b>		150	210
<b>Leaf parsley</b>		...	56
<b>Leaf lettuce</b>		6 - 8	21
<b>Radishes without leaves</b>		21	42
<b>String peppers</b>		...	60
<b>Green tomatoes</b>	10 - 15	21 - 28	65 - 70
<b>Fresh cucumbers</b>	2 - 3	21	42 - 50
<b>Asparagus</b>	2 - 3	1 - 5	21
<b>Green beans</b>	2 - 3	7	24
<b>Normative losses</b>		<b>40 %</b>	<b>3 %</b>

## Comparison with existing world analogues:

---

Unlike the existing world analogues that use open blowing of storage chambers with nitrogen to regulate the atmosphere, the technologies used in CWS are based on a fully closed gas separation scheme, which ensures their high economic efficiency compared to the existing world analogues in terms of energy consumption and cost.

The CWS has a separate two-parameter regulation of the atmospheric gas composition of carbon dioxide and oxygen:

WGS-U system performs membrane-free removal of carbon dioxide (CO<sub>2</sub>) - a product of fruit respiration - from the regulated atmosphere.

The technology is based on the use of gas separation ion-exchange membranes of special design, which provide selective removal of CO<sub>2</sub> from the chamber atmosphere, pumped over the membrane surface by a fan.

The membranes contain in their structure an immobilized, weakly basic chemisorbing group, which provides highly selective transfer (with CO selectivity coefficient<sub>2|N<sub>2</sub></sub> up to 70... 100 units) of CO<sub>2</sub> from the controlled nitrogen atmosphere of the chamber to the ambient air under the action of CO partial pressure difference  $\Delta p$  without application of compression or vacuum pumping of gases.

## Comparison with existing world analogues:

---

Structurally, selective membranes are designed as flat cassettes of filterpress type with airflow collectors, sealed by a special technology by pouring germopolymer and providing a packing density of the membrane working surface in the cassette up to 70 sq. m/l.

Energy consumption in the process of gas separation is reduced to the work of ventilation of chamber atmosphere and outside air, respectively, over adsorbing and desorbing membrane surfaces and is about 1.5 kWh/m<sup>3</sup> CO<sub>2</sub>, which is 2.5... 5 times lower than that of the best foreign analogues.

RGA - K system performs electrochemical removal of oxygen from the regulated atmosphere. The gas separation technology is an electrochemical oxygen "pump" cycle:

chamber atmosphere oxygen is chemically bound in the reaction of "cold" (+50...70°C) catalytic oxidation of hydrogen, which is generated at the cathode of electrolysis cells with a modern solid polymer electrolyte (sulfocationic ion exchange membrane);

the product of the oxidation reaction, water, returns to the electrolysis cells, where it decomposes into hydrogen, which is released at the cathode, and oxygen, which is released in its pure form

at the element anode and is released into the atmosphere or can be used for process needs. The nitrogen atmosphere purified from excess oxygen and CO<sub>2</sub> is returned to the storage chamber.

## Comparison with existing world analogues:

---

Energy consumption for extraction of pure oxygen from the regulated atmosphere does not depend on its concentration in the atmosphere (up to 0,5... 1% vol.) and amounts to 8...10 kWh/m<sup>3</sup> O<sub>2</sub>, which is 3...5 times lower than that of known analogues in the zone of oxygen concentration less than 5% and allows extending the regulation range to ultra-low concentrations, necessary for storage of perishable products.

As a part of the complex of storage means of atmospheric regulation SRGA for the purpose of unification are structurally executed in the form of modules with a capacity corresponding to storage of 50 tons of products.

In the process of completing the development of pilot technologies and sample systems, the following modifications of SRGA technological processes have been created in order to further improve their cost parameters and energy efficiency:

On the electrochemical technology of oxygen removal (RGA-K): the principle of boosting the performance of systems on oxygen pumping based on an additional working body (ethanol, propane) included in the main cycle of chemical-catalytic oxygen binding as a reducing agent in addition to electrochemical hydrogen is processed.

This modification of the technology makes it possible to increase by 3...4 times the productivity of RGA-K systems for the peak load period during formation of hypoxic atmosphere practically without increasing the capital cost of the main electrochemical equipment of RGA-K; at the same time the high ecological purity of the technology is preserved due to the presence of hydrogen, which significantly improves the kinetics of oxidation of additional working medium in the catalytic reactor of the modified system.

## Comparison with existing world analogues:

---

The comparison of achievable technical and economic characteristics of the modified RGA-KM system with the world analogues - membrane compressor systems of oxygen removal - of "Swan", "Monstanto", "Fighter" types, domestic "BARS", "Korsat" shows that in this case an additional gain is achieved in specific power consumption for gas separation in the mode of initial oxygen pumping (from 21% to 4%) to 2 - 5 times and in specific cost to 2 - 3 times compared with the best foreign analogues.

On non-compressor membrane technology of RGA-U systems: on the basis of a set of previously performed fundamental R&D by the project participant - ANPK "Technolog", three types of technologies for producing ion-exchange highly selective membranes with grafted weak basic group for non-compressor separation of carbon dioxide from air were investigated:

post-radiation grafting of styrene onto the polyethylene matrix, subsequent sulfation and partial neutralization with amines (Styropen membranes);

post-radiation grafting of the carboxylate group to polyethylene or fluoroplastic and neutralization with amines (Acroplen membranes);

- neutralization of the sulfo-amidopolymer solution in the aqueous phase by amines and pouring the chemoactive film in the liquid phase onto a porous polymer carrier substrate to form a composite gas separation membrane.

## Comparison with existing world analogues:

---

The obtained types of membranes equally have selectivity for CO<sub>2</sub> an order of magnitude higher than the existing in the world practice of industrial gas separation membranes, but the last modification of the technology represents the most extensive opportunities to increase gas permeability and, therefore, to reduce the working surface of membranes and the cost of membrane gas separation plants.

Comparative characteristics of the best world analogues operating on the principle of open blowing of storage chambers with nitrogen- enriched mixture, the proposed RGS systems (as part of CWS) have a pronounced competitiveness in Russia, CIS and third world countries. The features of the new systems are:

- fully closed recirculation scheme for regulating the gas composition of the storage atmosphere,

- no energy-intensive compression or vacuum pumping of gases during gas separation,

- absence of expendable working bodies in the main mode of operation.

These features determine the priority qualities of new technical means of RGS at the level of world analogues:

- Increasing energy efficiency by a factor of 2 to 5,

- Reduction of metal consumption and dimensions of RGS units,

- expansion of opportunities to regulate the gas composition - up to ultra-low oxygen concentrations (0.5% vol.), unattainable in the existing technologies of RGS systems.

# Typical plants constructions in industrial zone long-term storage:

---



It is important to preserve the crop and minimize storage losses.

# Typical plants constructions in industrial zone long-term storage:

---



It is important to preserve the crop and minimize storage losses.

Comprehensive solution: the zone of growing products, long-term storage area, the zone of phasing and processing of products and wholesale of grown products:

---

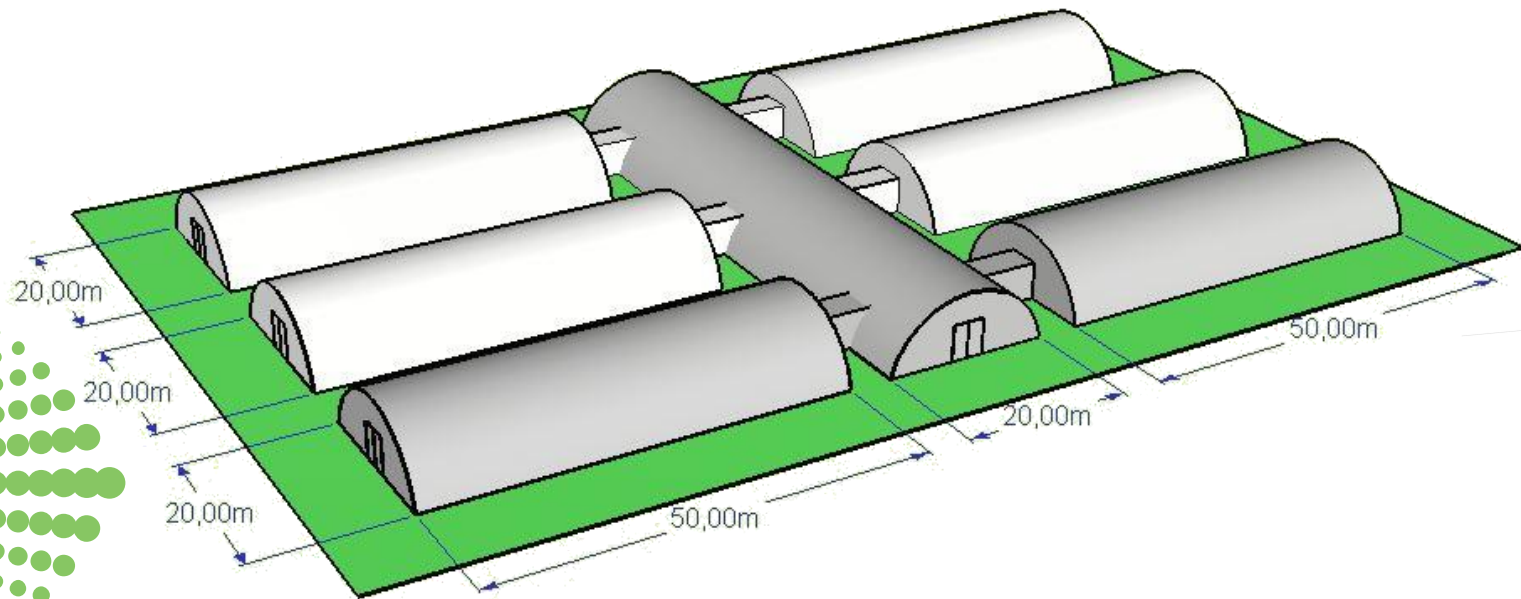

It is important to preserve the crop and minimize storage losses.